

SEWAGE PUMP - Stainless steel SUS316

SWA Series - 60Hz - 4 Pole, 230V, 460V, 575V



SWA series 4 pole



SSW series 2 pole

Product Description

SWA series has 10 models that offer:

- the auto-cut shuts off automatically to prevent over-heat whenever its voltage drop, impeller plugged, water level under the watermark and other unusual conditions
- cable base filled with EPOXY to raise humidity resistance
- world class innovative design pump
- suction casings made of chromium alloy steel
- double mechanical seal made of silicon carbide
- all O-rings made of nitrite rubber
- convenient to move pump from one site to another
- strict adherence to CE and UL standards
- three kinds of impellers, semi-open, closed, vortex are equipped for pumping various waste water treatment



Waste water treatment plant



SSW series 2 pole

* We reserve the right to amend specification without prior notice.

INDRA HYDRO TECH PUMPS PVT. LTD.

316, 1st Floor, 8th Cross, 4th Phase, Peenya Industrial Area, Bengaluru - 560 058, Karnataka, India
Tel.: +91 80 2836 2916, Fax: +91 80 2836 3048, Email: contact@ihpindia.in, www.ihpindia.in

SEWAGE PUMP - Stainless steel SUS316

SWA Series - 60Hz - 4 Pole, 230V, 460V, 575V



Sewage processing plant

Applications

- Wastewater lift station, municipal wastewater treatment plant.
- Building wastewater treatment system.
- Piggery excrement, animal & poultry farm.
- School, hospital, community wastewater treatment system.
- Food, paper, mining, textile, leather industry wastewater treatment system.

Models

Models	Phase	Pole	Models	Phase	Pole
SWA-333	3 Ø	4	SWA-3156	3 Ø	4
SWA-354	3 Ø	4	SWA-3206	3 Ø	4
SWA-3754	3 Ø	4	SWA-3208	3 Ø	4
SWA-3104	3 Ø	4	SWA-3256	3 Ø	4
SWA-3106	3 Ø	4	SWA-3308	3 Ø	4



Paper industry

Performance Curves

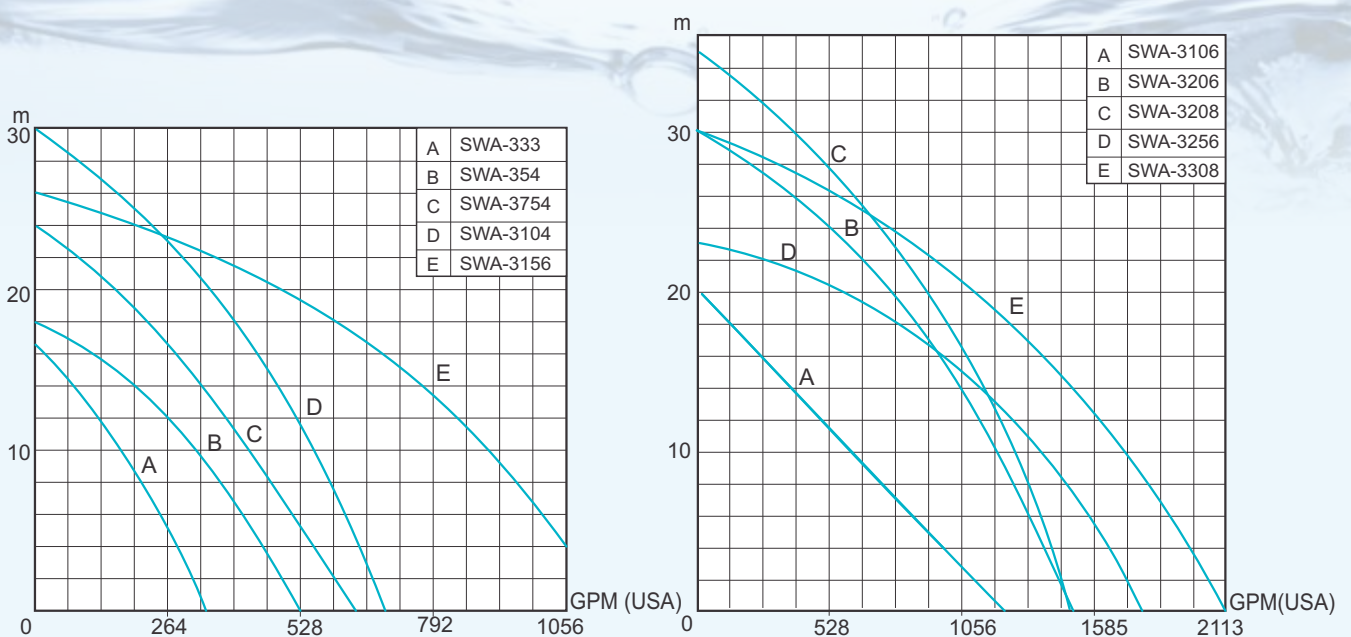

* We reserve the right to amend specification without prior notice.

INDRA HYDRO TECH PUMPS PVT. LTD.

316, 1st Floor, 8th Cross, 4th Phase, Peenya Industrial Area, Bengaluru - 560 058, Karnataka, India
 Tel.: +91 80 2836 2916, Fax: +91 80 2836 3048, Email: contact@ihpindia.in, www.ihpindia.in

SEWAGE PUMP - Stainless steel SUS316

SWA Series - 60Hz - 4 Pole, 230V, 460V, 575V



Specifications



Semi open impeller

Motor	Type	Submersible, Oil filled (continuous duty)	
	Pole	4-P	
	Insulation Class	H-class (180°C)	
	Frequency	60Hz	
	Protector	Auto-cut (Overheat & Overload)	
	Pole Rotation	4P/1800 RPM	
	Protection class	IP-68	
	Materials	Motor Casing Body	SUS 304
		Shaft	SUS 403/SUS 410/SUS 420
		Cable	CE/UL standard
Seal		SIC-Seal	
Pump	Outlet-mm	80. 100. 150. 200.	
	Impeller Type	Semi open, Channel, Vortex Impeller	
	Impeller Material	SUS-316	
	Mechanical Seal	Dual mechanical seal made of silicon carbide	
	Bearing	Heavy duty bearing	
	Maximum Depth	30-Mts	
	Liquid temperature	0~40°C (32° F - 104° F)	
	Volute Casing	SUS-316	
	Seal Bracket	SUS-316	
	Upper Cover	SUS-316	

Dimensions & Weight

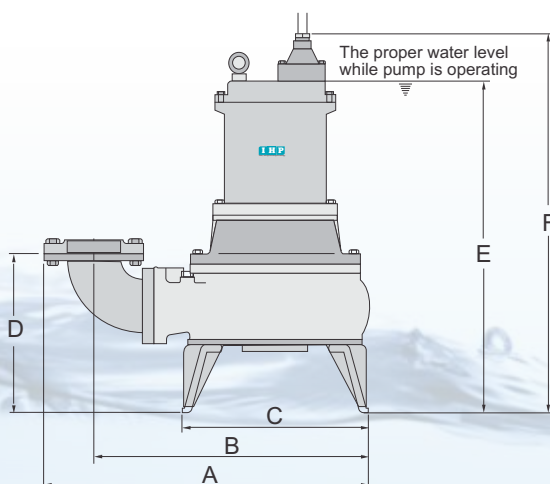

Unit : mm

TYPE	A	B	C	D	E	F
SWA-333	540	450	315	285	575	615
SWA-354	540	495	315	285	620	670
SWA-3754	685	580	395	340	700	710
SWA-3104	685	580	395	340	710	820
SWA-3106	685	580	450	540	890	870
SWA-3156	860	720	450	540	890	950
SWA-3206	860	720	450	540	940	950
SWA-3208	860	720	450	540	940	980
SWA-3256	890	740	510	615	970	980
SWA-3308	890	740	510	615	970	990

Hydraulic Data

Model	Output Hp(kW)	Outlet in inches	Voltage Range	Phase	Standards		Solid Passage mm	Max Diameter mm	Height mm	Weight kg.	Cable Meter
					Head m	Capacity m ³ /min					
SWA-333	3(2.2)	3"	230/460/575	3 ∅	10	0.6	40	580	615	80	10
SWA-354	5(3.7)	4"	230/460/575	3 ∅	11	1.0	40	580	670	86	10
SWA-3754	7½(5.5)	4"	230/460/575	3 ∅	14	1.0	30	600	710	108	10
SWA-3104	10(7.5)	4"	230/460/575	3 ∅	18	1.0	40	730	820	154	10
SWA-3106	10(7.5)	6"	230/460/575	3 ∅	12	2.5	45	850	870	184	10
SWA-3156	15(11)	6"	460/575	3 ∅	15	2.0	45	940	950	235	10
SWA-3206	20(15)	6"	460/575	3 ∅	20	2.5	55	940	950	245	10
SWA-3208	20(15)	8"	460/575	3 ∅	13	4.5	60	960	980	270	10
SWA-3256	25(19)	6"	460/575	3 ∅	25	3.0	55	940	980	280	10
SWA-3308	30(22.5)	8"	460/575	3 ∅	19	4.5	60	960	990	300	10

* We reserve the right to amend specification without prior notice.

INDRA HYDRO TECH PUMPS PVT. LTD.

316, 1st Floor, 8th Cross, 4th Phase, Peenya Industrial Area, Bengaluru - 560 058, Karnataka, India
Tel.: +91 80 2836 2916, Fax: +91 80 2836 3048, Email: contact@ihpindia.in, www.ihpindia.in



water, sewage and sludge technology
pumps for life ...

An ISO 9001:2008 certified company by 



INDRA HYDRO TECH PUMPS PVT. LTD.

316, 1st Floor, 8th Cross, 4th Phase
Peenya Industrial Area
Bengaluru - 560 058
Karnataka, India
Tel.: +91 80 2836 2916
Fax: +91 80 2836 3048
Email: contact@ihpindia.in



www.ihpindia.in